

# Hand pallet truck 3.0 ton

## BT lifter



# Hand pallet truck

Truck specifications					LHM300
Identification	1.1	Manufacturer			BT
	1.2	Manufacturer's type designation			LHM300
	1.4	Operator type			Hand
	1.5	Load capacity/rated load	Q(t)	kg	3000
	1.6	Load centre distance	c	mm	600
	1.8	Load distance, centre of drive axle to fork	x	mm	970 <sup>1)</sup>
	1.9	Wheelbase	y	mm	1185 <sup>1)</sup>
Weight	2.1	Service weight		kg	105
	2.2	Axle load, with load, drive/castor/fork wheel		kg	489/1050
	2.3	Axle load, without load, drive/castor/fork wheel		kg	26/13
Wheels	3.1	Steer/fork wheels: Powerthane (Po), Steel (S) Nylon (N), Polyurethane (P), Rubber (R), Rubber antistatic (Ra), Vulkollan (Vu)			Po, S, N, R, Ra/ Vu, N,
	3.2	Wheel size, front			175x60
	3.3	Wheel size, rear			85x75
	3.5	Wheels, number front/rear (x=driven wheels)			2/4
	3.6	Track width, front	b <sub>10</sub>	mm	132
	3.7	Track width, rear	b <sub>11</sub>	mm	340
	Dimensions	4.4	Lift	h <sub>3</sub>	mm
		Lift height	h <sub>23</sub>	mm	200
4.9		Height of tiller in drive position, min./max.	h <sub>14</sub>	mm	1220
4.15		Height, lowered	h <sub>13</sub>	mm	85
4.19		Overall length	l <sub>1</sub>	mm	1510
4.20		Length to face of forks	l <sub>2</sub>	mm	365
4.21		Overall width	b <sub>1</sub> /b <sub>2</sub>	mm	520/685 <sup>2)</sup>
4.22		Fork dimensions	s/e/l	mm	45/175/1150 <sup>3)</sup>
4.25		Width over forks	b <sub>5</sub>	mm	520/685 <sup>2)</sup>
4.32		Ground clearance, centre of wheelbase	m <sub>2</sub>	mm	40
4.33		Aisle width for pallets 1000 x 1200 crossways	A <sub>st</sub>	mm	1540 <sup>1)</sup>
4.34		Aisle width for pallets 800 x 1200 lengthways	A <sub>st</sub>	mm	1740 <sup>1)</sup>
4.35		Turning radius	W <sub>a</sub>	mm	1385 <sup>1)</sup>

1) Distance with forks raised

2) Other widths available on request

3) Other fork length available: 1220 mm. Other fork lengths on request.

All data are based on table configuration. Other configurations may give other values.

Truck performance and dimensions are nominal and subject to tolerances.

Specifications are subject to change without notice.

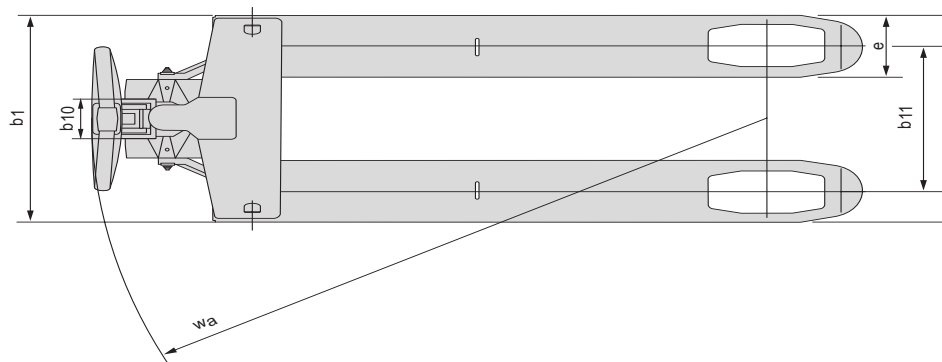
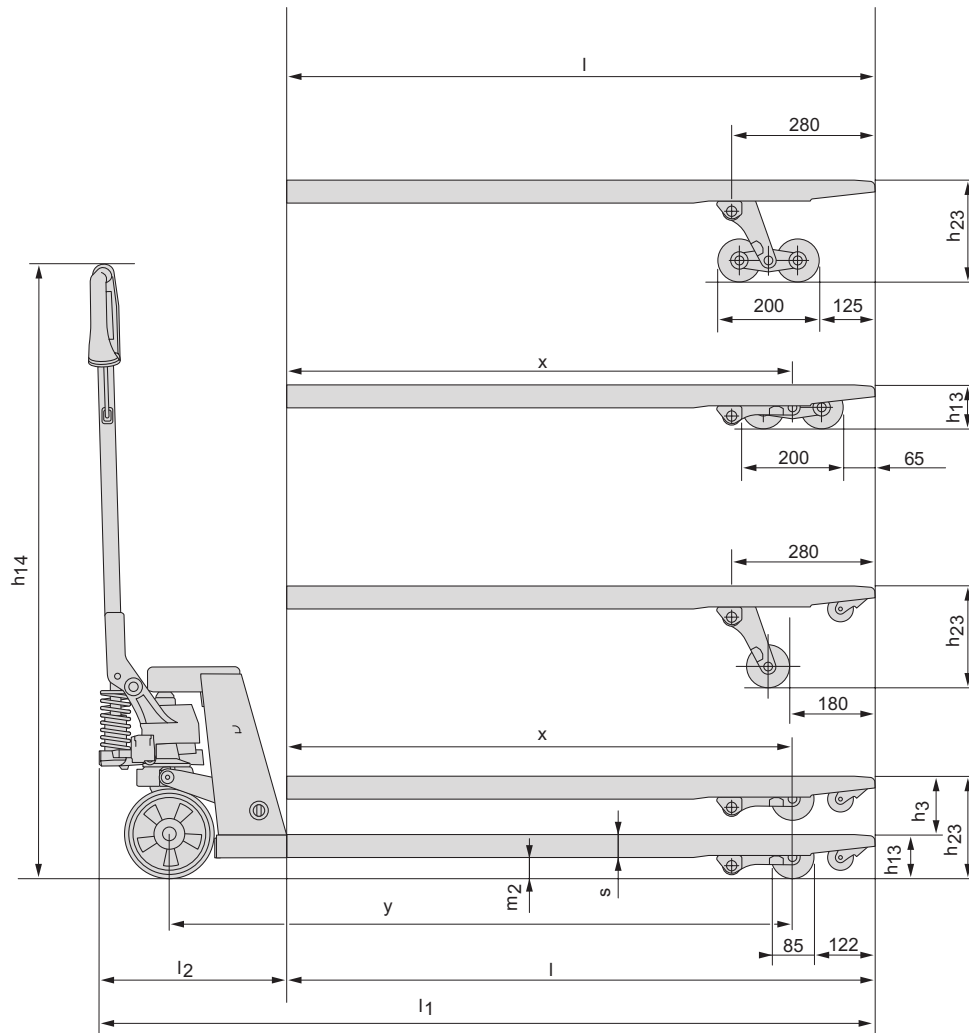

---

## Truck features:

- Angled high strength polymer handle for best ergonomic grip.
- BT lowering control valve enables smooth, controlled lowering action.
- Strong powerful thrust bearing is standard, for easier steering and enhanced durability.
- Greasable bushings ensure a long service life.



TP-Technical Publications, Sweden — 745342-040, version 1, 0908