

Hand pallet truck 1.0 ton

BT lifter

Ultra Low

LHM100UL



Hand pallet truck

Truck specifications					LHM100UL	LHM100UL	LHM100UL	LHM100UL
Identification	1.1	Manufacturer			BT	BT	BT	BT
	1.2	Manufacturer's type designation			LHM100UL	LHM100UL	LHM100UL	LHM100UL
	1.4	Operator type			Hand	Hand	Hand	Hand
	1.5	Load capacity/rated load	Q(t)	kg	1000	1000	1000	1000
	1.6	Load centre distance	c	mm	300	400	600	1000
	1.8	Load distance, centre of drive axle to fork	x	mm	330 ¹⁾	530 ¹⁾	880 ¹⁾	1730 ¹⁾
	1.9	Wheelbase	y	mm	580 ¹⁾	780 ¹⁾	1130 ¹⁾	1980 ¹⁾
Weight	2.1	Service weight		kg	58	64	80	125
Wheels	3.1	Steer/fork wheels: Steel (S), Nylon (N), Polyurethane (P)			N/P, S	N/P, S	N/P, S	N/P, S
	3.2	Wheel size, front			175x60	175x60	175x60	175x60
	3.3	Wheel size, rear			—/38x76 ²⁾	—/38x76 ²⁾	—/38x76 ²⁾	—/38x76 ²⁾
	3.5	Wheels, number front/rear (x=driven wheels)			2/4	2/4	2/4	2/4
	3.6	Track width, front	b ₁₀	mm	132	132	132	132
	3.7	Track width, rear	b ₁₁	mm	364	364	364	364
Dimensions	4.4	Lift	h ₃	mm	100	100	100	100
		Lift height	h ₂₃	mm	138	138	138	138
	4.9	Height of tiller in drive position	h ₁₄	mm	1220	1220	1220	1220
	4.15	Height, lowered	h ₁₃	mm	38	38	38	38
	4.19	Overall length	l ₁	mm	970	1170	1520	2370
	4.20	Length to face of forks	l ₂	mm	370	370	370	370
	4.21	Overall width	b ₁ /b ₂	mm	520	520	520	520
	4.22	Fork dimensions	s/e/l	mm	38/156/600	38/156/800	38/156/1150	38/156/2000
	4.25	Width over forks	b ₅	mm	520	520	520	685
	4.32	Ground clearance, centre of wheelbase	m ₂	mm	5	5	5	5
	4.33	Aisle width for pallets 1000 x 1200 crossways	A _{st}	mm	—	—	1595 ¹⁾	—
	4.34	Aisle width for pallets 800 x 1200 lengthways	A _{st}	mm	—	—	1795 ¹⁾	—
4.35	Turning radius	W _a	mm	825 ¹⁾	1025 ¹⁾	1375 ¹⁾	2225 ¹⁾	
Others		Support wheels			No	No	No	Yes/Nylon
		Outside width of steel arm for support wheels		mm	—	—	—	685
		Pump unit			Quicklift, overload			

1) Distance with forks raised

2) Singel wheel / Boggie wheel

All data are based on table configuration. Other configurations may give other values.

Truck performance and dimensions are nominal and subject to tolerances.

Specifications are subject to change without notice.

Dimensional drawings

BT lifter

Ultra Low

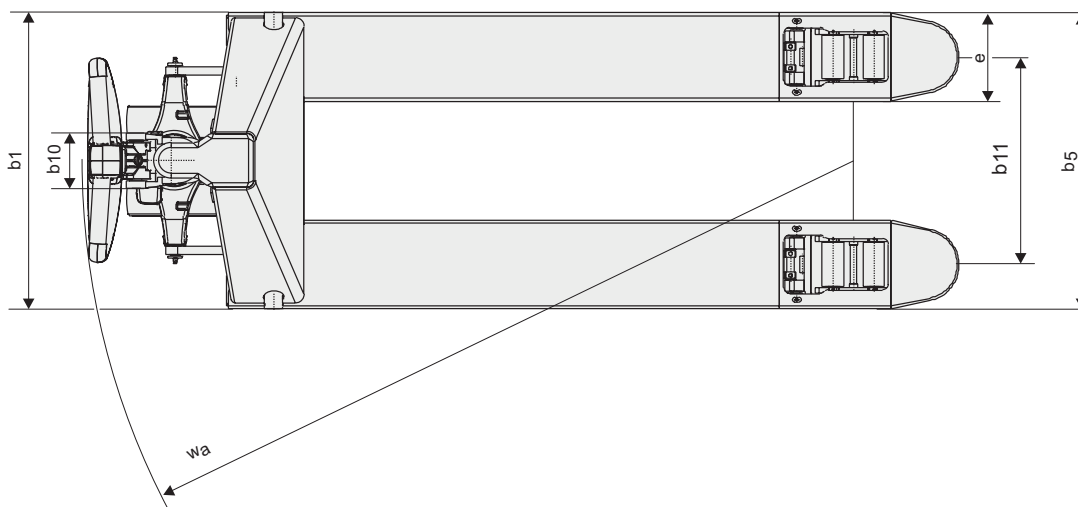
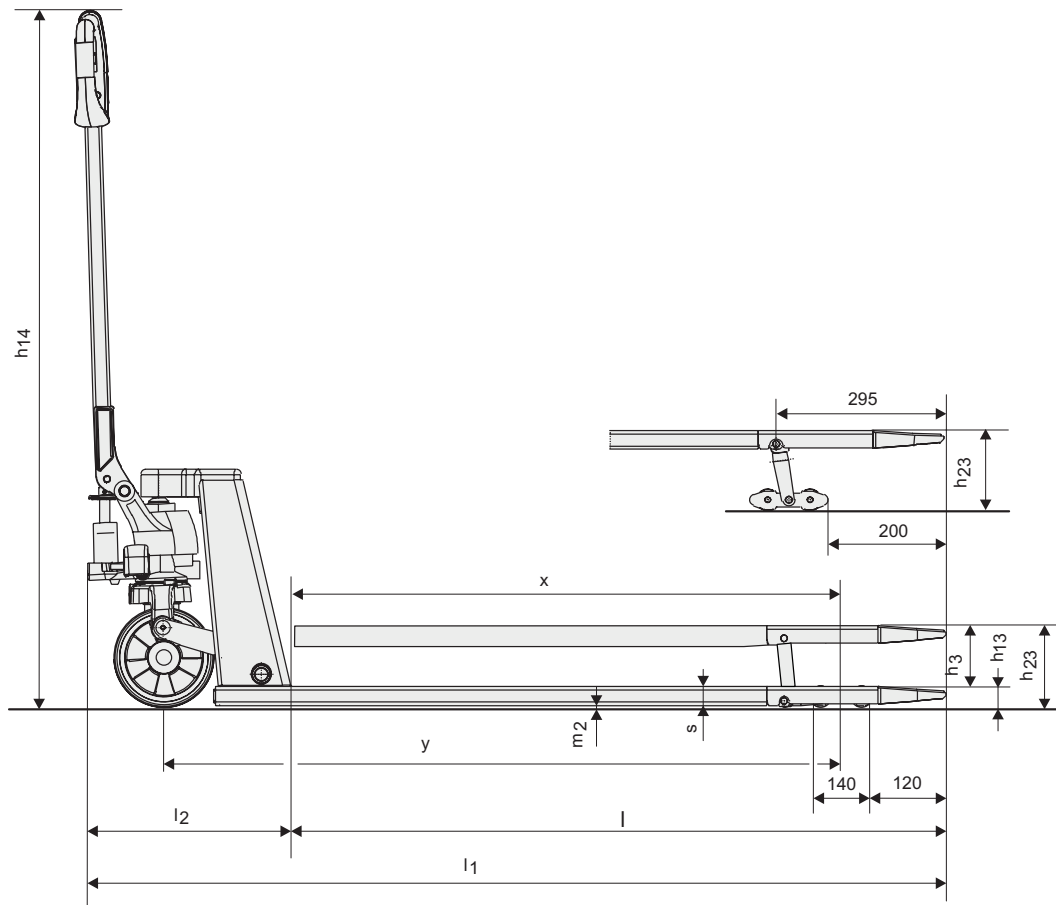

Truck features:

- Designed for load carriers with very low pallet tunnels.
- Despite low minimum fork height, capable of lifting a standard EUR pallet.
- Quick Lift function is standard.
- Fork tips are chamfered for easy climbing over small objects.
- Customized configurations – a part of our offer.
- Robust design and still low weight – easy to manoeuvre.
- Powder coating give a high and even finish.
- Angled high strength polymer handle for best ergonomic grip.
- BT lowering control valve enables smooth, controlled lowering action.
- Strong powerful thrust bearing is standard, for easier steering and enhanced durability
- Greasable bushings ensure long service life.
- Quick lift and overload can be combined.
- This product has been environmentally declared.



TP-Technical Publications, Sweden — 745351-040, version 5, 1305